

ANGULAR DEFLECTION

Drain Movement Compensation
for Reactive Soils as per:
AS/NZS3500.2 2012
AS/NZS2032.2006.
AS2870.2011

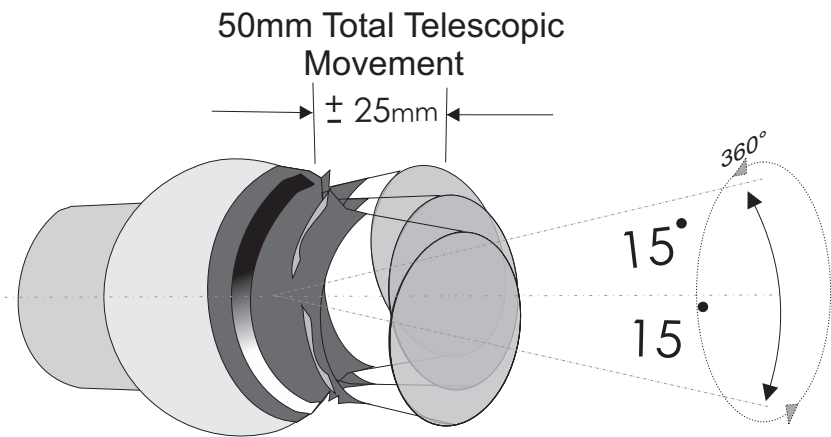
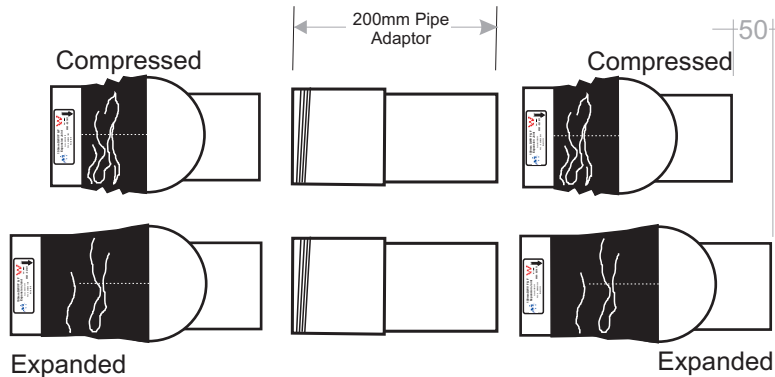
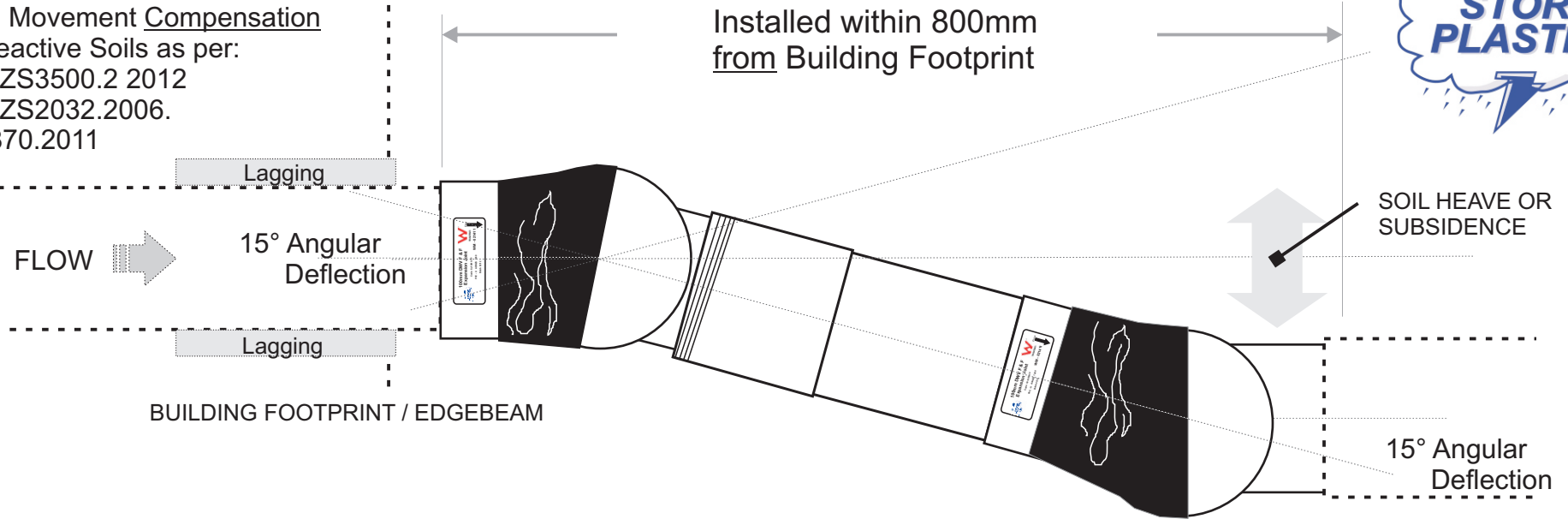

SJ10015 Angular and Telescopic Swivel

Installation:
Assemble and solvent weld units.

Expand both Swivels fully (50mm)
then close ½ way (25mm).

Install on grade in reactive soils
of 1:40 where possible.